

SYMB	REVISION	DATE	APVD.	SYMB	REVISION	DATE	APVD.	VERSION: 2	F2A-49-1/1	
								MODE	Tactile Feedback	
								TIMING		
								LINE(S)	CIRCUIT	STROKE
								1	1P1T	0.2

Without any banned substance! Compliance with RoHS!

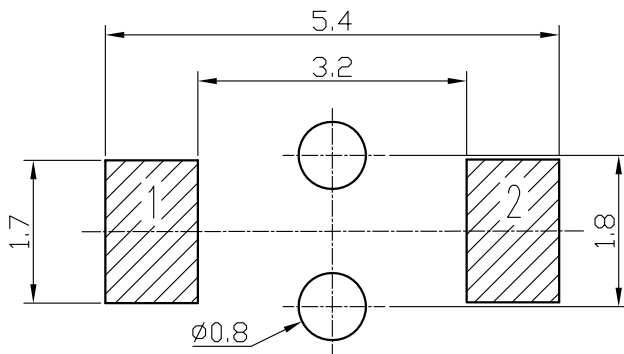

Recommended PAD Layout $\oplus\pm 0.05$
TOP VIEW

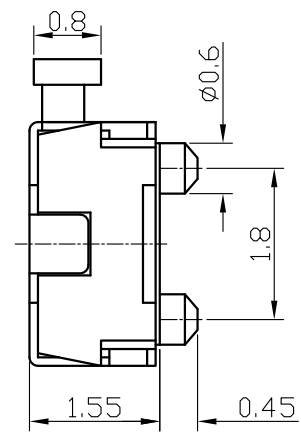
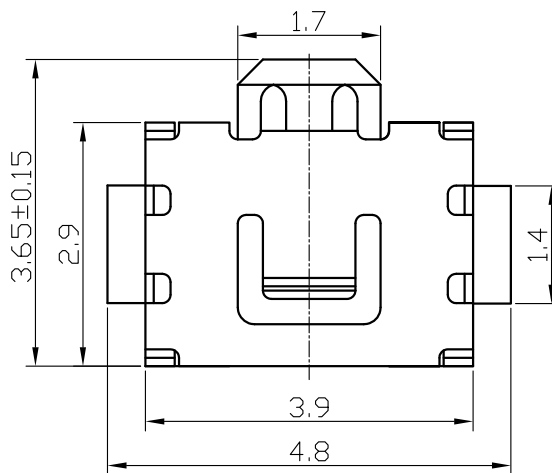
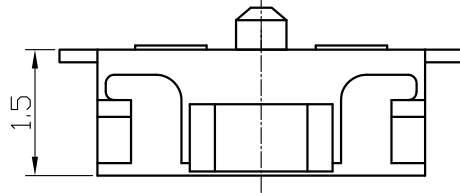
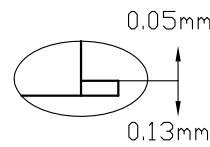

COPPLANARITY

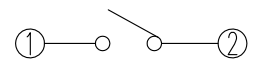



CIRCUIT DIAGRAM



PACKING DETAIL



<QTY:4000PCS/REEL>

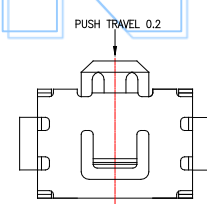
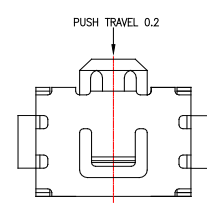

TYPE	TACT SWITCH	UNIT	mm	9					
SERIES	TSM-035510	SCALE	14:1	8					
PART NO.	TSM-035510-220	DATE	12/04/06	7					
SPEC. NO.	SETD01681	PAGE	1/6	6					
DRAWN	CHECKED	APVD.	TOLERANCE		5	TERMINAL 1,2	PBS	2	Ag PLATED
			ANGLE	$\pm 3^\circ$	4	COVER	SUS	1	NATURE
			UP TO 1	± 0.1	3	STEM	PA6T	1	BLACK
			ABOVE 1 ~ 5	± 0.2	2	CONTACT	SUS	2	Ag CLAD
			ABOVE 5 ~ 50	± 0.3	1	CASE	LCP	1	WHITE
SANWIN ELECTRONIC TECHNOLOGY CO. LTD.					NO.	NAME	MATERIAL	QTY.	FINISHING

產品規格書				檔編號No. :	頁數Page	
SPECIFICATION				SETD01681	P2/6	
產品類別Type:	輕觸開關Tact Switch			Prepared	Checked	Approved
產品系列Series:	TSM-035510	版本Version:	1			
產品編號Part No.:	TSM-035510-220	日期Date:	2012/4/16			
1. 通則 General Characteristics:						
1.1 應用範圍 Application range: 此產品規格書適用於輕觸開關TSM-035510。 This product specification is applied to the TSM-035510 Tact Switch.						
1.2 使用環境條件 Acclimatization: 使用溫度範圍 Operating Temperature rang:-20°C ~ 70°C 保存溫度範圍 Preservative Temperature:-30 ~ 80°C						
1.3 測試條件Test Conditions: 若沒有特別說明，則試驗條件如下： Unless otherwise specified,the atmospheric for marking measurements and tests are as follows: 溫 度 Temperature:20±2°C 相對濕度 Relative Humidity:45 ~ 85% 氣 壓 Air pressure:86 ~ 106Kpa 如對判定產生疑義，則試驗按以下條件進行： However,if the decision based on the measurements suspicion conditions, the following conditions shall be employed: 溫 度 Temperature:20±2°C 相對濕度 Relative Humidity:65±5% 氣 壓 Air pressure:86 ~ 106Kpa						
2. 外觀和安裝尺寸 Appearance & Mounting Dimensions:						
2.1 外觀 Appearance: 產品外觀良好，無破損、銹蝕、裂紋和鍍層缺陷。 The switch shall have good finishing,and no rust,crack plating defects.						
2.2 安裝尺寸Mounting dimensions: 應符合產品設計要求，詳見成品圖。 Should comply with the design requirements of products, see the finished product drawing.						
3. 驅動方式Operate Mode:						
按鈕式：中間方向（如成品圖所示） Push Button:Center (as assembly drawing shown).						
4. 回路方式 Circuit Mode:						
如成品圖所示 (as assembly drawing).						
5. 額定負荷及壽命 Rating and Ooerating life.						
額定負荷 Rating:DC 12V,50mA Max 機械壽命 Mechanical life:50,000次						
6 電氣性能Electrical Characteristics						
專案Item	測試條件Test Method			標準Criteria		
6.1 接觸電阻 Contact Resistsnce	以10mA 5V DC 或者 1KHz±200Hz(20mV max , 50mA max) 下採用電壓降法測量。 Shall be measure at 1KHZ±200Hz (20mV max,50mA max) or DC 5V 10mA by voltage drop method.			常態 Normal 100mΩ以下 100mΩ max 氣候及壽命試以後 After climate and life test. 200mΩ以下 200mΩ max		



產品規格書 SPECIFICATION				檔編號No. :	頁數Page	
產品類別Type: 輕觸開關Tact Switch				Prepared	Checked	Approved
產品系列Series:	TSM-035510	版本Version:	1			
產品編號Part No.:	TSM-035510-220	日期Date:	2012/4/16			
6.2 絕緣阻抗 Insulation Resistance	在相互絕緣的所有端子之間及各接線端子與外露的非載流金屬零件之間加載100V DC ,持續時間60±5S. DC 100V voltage is applied between each pair of terminals and between the terminal and the metal frame for 60±5S.			常態 Normal 100MΩ以上 100MΩ Min 氣候及壽命試以後 After climate and life test. 10MΩ以上 10MΩmin		
6.3 抗電強度 Dielectric Strength	在相互絕緣的所有接線端子之間加載250V (50 ~ 60Hz洩漏電流2mA) 的交流電, 各接線端子與外殼或非載流金屬零件之間加載250V(50 ~ 60Hz)電流 洩漏2mA交流電, 持續時間60±5S。 AC 250V(50-60Hz)2mA alternate current load is applied between open terminals connected with wires or 250V (50-60Hz),2mA Alternate current load for 60±5S.			無擊穿和飛弧現象 The switch without dielectric breakdown and fly arc phenomenon.		
7 機械性能 Mechanical Characteristics						
專案Item	測試條件Test Method			標準 Criteria		
7.1 操作力 Operating Force	按規定的操作方法給操作柄施加壓力 Push by recommended operating condition.			中間方向center: 220±80gf.		
						
7.2 行程 Travels	開關發生轉換後, 操作元件末端之間與初始位置之間的距離。 Distance from the end of operating component to the position when switch is being transformed.			中心正接Center push: 0.2±0.1mm		
						

產品規格書				檔編號No. :	頁數Page	
SPECIFICATION				SETD01681	P4/6	
產品類別Type:	輕觸開關Tact Switch			Prepared	Checked	Approved
產品系列Series:	TSM-035510	版本Version:	1			
產品編號Part No.:	TSM-035510-220	日期Date:	2012/4/16			
7.3 操作件強度 Operating Part Strength	置開關於正常安裝位置，在操作件中心施加與操作件動作相同方向的1kg靜負荷，時間為60 ±5S。 Put the switch in the normal gearing position,Bring 1kgf pressure which direction is similar to the actuator operates direction in the tip of the actuator center ,time is 60±5S.			無機械和電氣損傷。 The switch shall be free from mechanical and electrical damage.		
7.4 振動 Vibration Proof	開關採用常規安裝方法牢固地安裝在實驗設備上，按下述參數進行實驗： 1) 振頻：10-55Hz 2) 振幅：1.5mm 3) 振動變化速率：10 ~ 55 ~ 10Hz 大約1分鐘 4) 變頻方法：線形方式 5) 振動方向：三個互相垂直的方向，其中一個方向為 操作元件運動的方向。 Switch shall be secured to a testing machine by a normal mountingdevice and method,,Switch shall be measured after following test: 1)Vibration frequency range:10 ~ 55Hz. 2) Total amplitude:1.5mm 3)Sweep ratio:10 ~ 55 ~ 10Hz,Approx 1 minute 4)Method of changing the sweep vibration frequency linear. 5)Direction of vibration:Three perpendicular directions includng actuating direction.			符合第6.1、6.2、6.3第7.1條要求。 According to item 6.1、6.2、6.3 and 7.1 to examine.		
7.5 衝擊 Impact shock test	1)加速度 Acceleration : 80G 2)衝擊次數：六個方向3次，共18次 2)Cycle of test:3cycles each in 6 directions,for a total 18 cycles.					
8 耐候試驗 Weather Proof Characteristics						
專案Item	測試條件 Test method			標準Criteria		
8.1 高溫 Hot Proof	試件在80±2°C的溫控箱內保持48小時，然後在正常溫度和濕度下恢復1小時，並在此後的1小時內對試件進行測量，水滴應消失。 After testing at 80±2°C for 48 hours,the switch shall be allowed to stand under normal temperature and humidity conditions for 1 hour and measurement shall be made with 1 hour after that,water drops shall be eliminated.			符合第6.1、6.2、6.3第7.1條要求。 According to item 6.1、6.2、6.3 and 7.1to examine.		

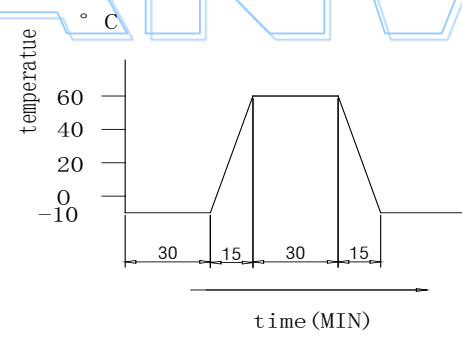
產品規格書 SPECIFICATION				檔編號No. :	頁數Page	
產品類別Type:		輕觸開關Tact Switch		Prepared	Checked	Approved
產品系列Series:	TSM-035510	版本Version:	1			
產品編號Part No.:	TSM-035510-220	日期Date:	2012/4/16			
8.2 恒定濕熱 Moisture Resistance	<p>試件在60±2°C,90~95%RH的溫控箱內保持48小時，然後在正常溫度和濕度下恢復1小時，並在此後的1小時內對試件進行測量，水滴應消失。</p> <p>After testing at 60±2°C,90~95%RH for 48 hours,the switch shall be allowed to stand under normal temperature and humidity conditions for 1 hour and measurement shall be made with 1 hour after that, Water drops shall be eliminated.</p>			<p>符合第6.1、6.2、6.3第7.1條要求。</p> <p>According to item 6.1、6.2、6.3 and 7.1to examine.</p>		
8.3 低溫 Cold Proof	<p>試件在-40±2°C的溫控箱內保持48小時，然後在正常溫度和濕度下恢復1小時，並在此後的1小時內對試件進行測量，水滴應消失。</p> <p>After testing at -40±2°C for 48 hours,the switch shall be allowed to stand under normal temperature and humidity conditions for 1 hour and measurement shall be made with 1 hour after that, water drops shall be eliminated.</p>					
8.4 溫度轉換 Temperature Cycling	<p>試件按下述試驗條件試驗5個迴圈，然後在正常溫度和濕度下恢復1小時，並在此後的1小時內對試件進行測量，水滴應消失。</p> <p>After 5 cycles of following conditions,the switch shall be allowed to stand under normal temperature and humidity conditions for 1 hour after that Water drops shall be eliminated.</p> 					
9 耐久性試驗 Durability Characteristics						
專案Item	測試條件 Test method			標準Criteria		
9.1 壽命試驗 Operating Life	<p>1)在不帶負荷的條件下，在壽命測試設備上連續轉換50,000次，頻率：120-160次/分鐘。</p> <p>1)50,000 cycles of operation shall be performed continuously cycles without load at a rate of 120-160 cycles per minute.</p>			<p>動作力：初始值的±30%</p> <p>Operating force:within ±30% initialization value.</p> <p>彈跳 10 ms Max</p> <p>Bounce 10 ms Max</p> <p>其餘符合第6.1、6.2、6.3、7.1條</p> <p>Etceteras according to item 6.1, 6.2、6.3 ,7.1 to examine.</p>		

產品規格書				檔編號No. :	頁數Page	
SPECIFICATION				SETD01681	P6/6	
產品類別Type:	輕觸開關Tact Switch			Prepared	Checked	Approved
產品系列Series:	TSM-035510	版本Version:	1	李 晓斌	任 明华	梁 成元
產品編號Part No.:	TSM-035510-220	日期Date:	2012/4/16			

10. 焊接Soldering

專案Item	測試條件 Test method	標準Criteria
101 耐焊接熱 Solder Heat Resistance	<p>試件在下列條件下進行試驗：</p> <p>1) 焊接溫度:260±5℃；</p> <p>2) 焊接時間：5±1S;</p> <p>3) 熔錫面積：PCB板厚度的一半 (PCB：t=1.6)。</p> <p>Specimen shall be checked in the following conditions test:</p> <p>1)Soldering temperature:260±5℃；</p> <p>2)Soldering time:5±1S;</p> <p>3)Soldering area：1/2 of PCB board thickness(PCB:t=1.6).</p>	<p>無機械和電氣損傷。</p> <p>The switch shall be free from mechanical and electrical damage.</p>
10.2 回流焊 Reflow Soldering		<p>外觀無裂開、鬆動等異常現象，滿足於電氣性能。</p> <p>Without deformation of frame or excessive lossness of terminals, Electrical performance shall be satisfied.</p>
10.3 可焊性 Solderbilty	<p>焊接溫度：245±5℃</p> <p>Solder temperature: 245 ±5℃.</p> <p>浸漬時間：3 ±0.5S</p> <p>Dipping time: 3 ±0.5 second.</p>	<p>超過90%的浸漬覆蓋焊接。</p> <p>More than 90% of the dipping covered by solder.</p>